

# 135 CAMERA 28mm LENS INSTRUCTION

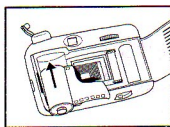

- 1) Using lens cover switch, open lens cover
- 2) Using back cover latch, open camera back
- 3) Lift lever of film rewind crank and pull crank upwards to remove rewind shaft out of the film chamber.
- 4) Drop film into chamber and push rewind crank back into place to engage the rewind shaft into the film cartridge.

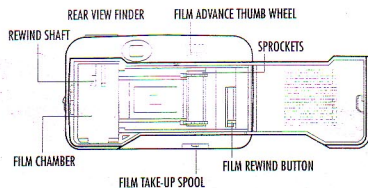
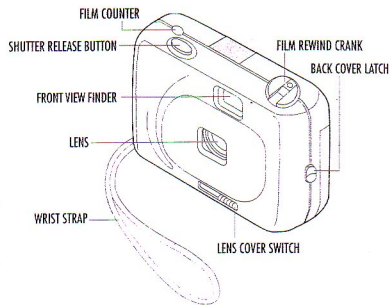
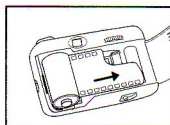

- 5) Pull out enough film so that the tip of the film leader is just inserted into the slot on the film take up spool.
- 6) Press the shutter release button and wind on the film by turning the film advance thumb wheel until it locks. Make sure the film is lying flat across the back of the camera and the sprockets are engaged in the film holes. The film should have wound around the take up spool. If not, repeat this step.



- 7) Repeat step 6 and close back cover firmly.
- 8) Continue step 6 until number "1" appears in film counter.
- 9) To take pictures, look through view finder to compose picture (recommended distance to subject is 1m (3') to infinity), hold the camera steady and press shutter release button gently. Keep hair and fingers away from the lens.

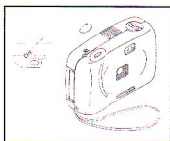

- 10) After assembly, final check up of all component parts to ensure normal functioning.

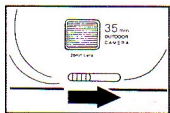

- 11) Open the lens cover by sliding the knob to the right, and compose the picture. With this camera's viewfinder, you can leave your eyeglasses off or on.

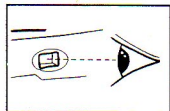

- 12) Keep your eye in the center of the View Finder. Make sure your subject is at least 3 ft. (1m) from the camera.

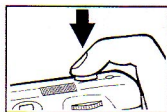

- 13) Look through the viewfinder, and press the Shutter Release Button. Apply light, but steady pressure with your index finger to avoid camera shake that might result in image blur.

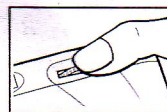

- 14) Turn the Film advance Thumb Wheel as much as it will go, to advance the film to the next frame and ready the camera for the next shot. Do not apply excessive pressure in turning the wheel. If you cannot turn the wheel, the film is at the end - you should then rewind the film (see UNLOADING THE FILM).

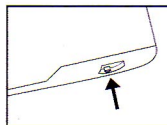

- 15) At the end of the film, the film advance thumb wheel will no longer turn. **FILM MUST BE REWOUND BEFORE BEING REMOVED FROM CAMERA.**
- 16) Press film rewind button in and hold it there whilst turning film rewind crank in the direction of the arrow. When film is truly rewound, the crank will become easy to turn.

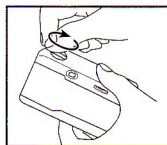

- 17) Open camera back, pull film rewind crank out and remove film for processing as soon as possible.
- 18) For flash photographs, slide base of flash gun (not supplied) into hot shoe. Take pictures as in point 9 above, but note recommended distance is no more than 3m (10')

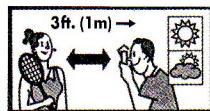

## 相機裝嵌說明

工作前請詳讀本說明。

本機共由 44 個不同材料的零件組成，其中：

1. 塑膠零件 33 件 1 - 33 (詳見塑膠零件編號圖)
2. 彈簧 4 件 S36 - S39
3. 手挽帶 1 件 40
4. 螺絲 6 粒

裝機前應清點，並保管好所有零件，不能遺失短缺零件。

塑膠零件中有 3 件透明鏡片零件 (30-32-33) 需特別注意保管。各鏡片正反兩面均不可用手直接觸及，需要時應用清潔柔軟的紙或布墊著手指才可觸及。更不能與硬物摩擦，裝嵌時應夾住兩側面。

裝嵌應按照付圖所示之先後順序進行，在同一工序中，若有多個零件裝配時須按照圖中所示 ①, ②, ③ ..... 順序進行。(未標出的工序可不分先後隨意進行)

## Installation Guide

Study carefully for the instruction before you start working.

Check that the following accessories are supplied 44 piece different parts with your camera kit.

1. 33 pieces of plastic parts. (1-33) (see the part no. are show on the parts pad)
2. 4 pieces of spring (S36 - S39)
3. 1 piece of hand strap. (40)
4. 6 pieces of screws.

Make sure the parts and accessories quantity before install the camera. Do not missing any part.

Besides it has 3 pieces of lens parts, (30-32-33) Which should be keep it safty. Do not use finger to touch it directly. It will be damaged if you use the hard material to press it. Hold two sides when install the lens, always use soft cotton for cleaning.

According to the fig. instruction to install your camera kit, follow the right direction as ①, ②, ③, ..... step by step.

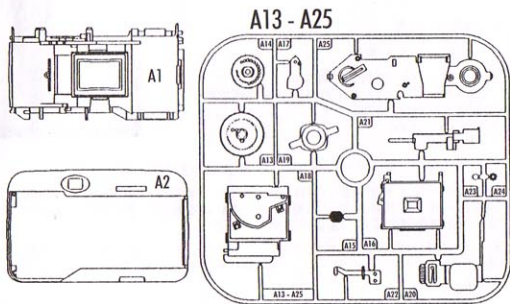

A13 - A25

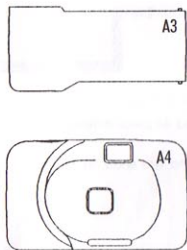

P5 - P12

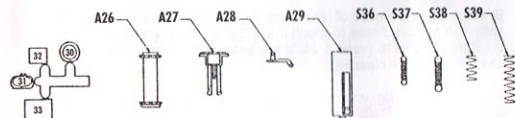
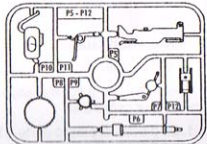

正確的裝配後，  
左右方向應能輕鬆自由滑動。

After correct installation,  
part 24 should be slide clockwise  
and anti-clockwise with ease.

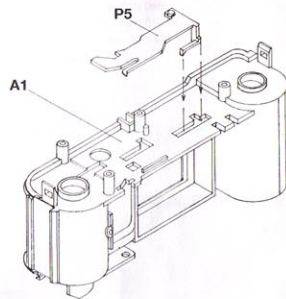

注意裝件 S37 時，上下方向不能裝錯。  
Make sure the correct positioning of part S37.

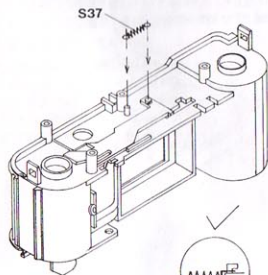

注意裝件 A26 兩端不一樣，若方向裝錯，  
則裝 P6 就不能插到應有的位置。(A26 大孔向上。)

To insert part A26 into the assigned position,  
make sure that two ends of part P6 was put in correction  
direction. (part A26 large hole position upward.)

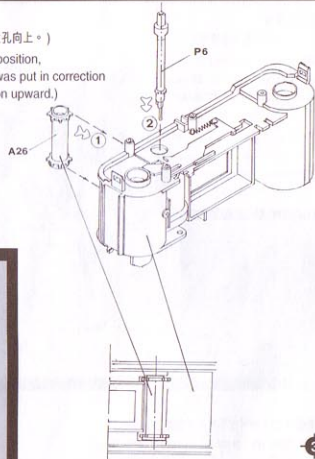

3

把 P7 扣上。  
Install P7 to indication.

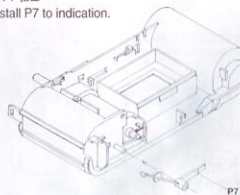

4

裝件 A25 時注意兩端扣位用力方是不一樣的。  
To assemble part A25 into the main system,  
special attention should be made on the  
different locks structure on sides.

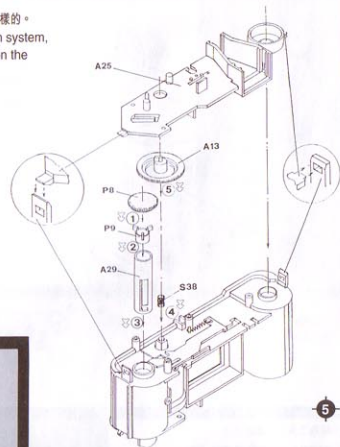

5

裝件 A16 時，先使兩角插入件 A1 的相應孔內，  
在向下 (B 位) 用力壓下，使扣位扣緊，  
裝 S36 彈簧時注意方向。

To assemble part A16, insert its two  
exterior corners into the respective  
holes in part A1. Press downward  
toward direction B to ensure a  
secure lock. Make sure the right  
direction when installing part S36.

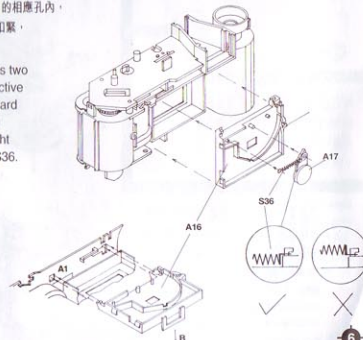

6

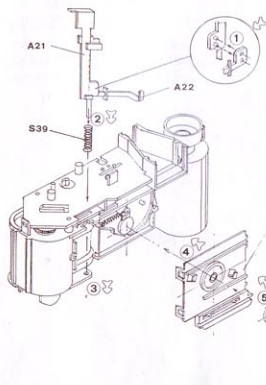

裝件 A18 之前須先把件 A22 套在件 A21 上再  
在件 A1 之孔內，件 A18 四角扣位必須扣緊，  
注意件 30 必須清潔不能有細小灰塵，裝件 A19  
時用力壓下且順時針方向旋轉扣好兩端扣位。

Before installing part A18, ensure a right  
assembly of part A22, secure locks on  
four corners of part A18 and a dirt-free  
part 30. Press down part A19,  
move clockwise until  
successful locks on two ends.

7

用隨機工具上緊螺絲 S35。  
Employ the bundled tools for  
fastening of screws.

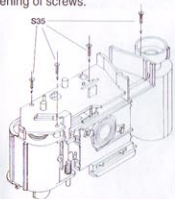

8

須注意件 32、33 清潔不能粘付灰塵，  
水口位向上方，另裝 A15 至 A14 數字盤上  
方便以後可順時針方向轉動。  
Ensure part 32 and part 33 are  
free of dirt. Make sure the right  
direction of part A15. Correct  
installation of it enables moving  
clockwise.

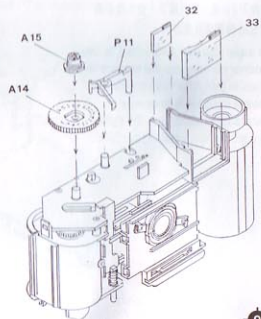

9

16

裝上門扣 P10。  
Install back cover button P10.

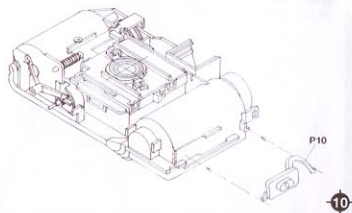

10

把 A3 套入 A2 內。  
Put A3 into A2.

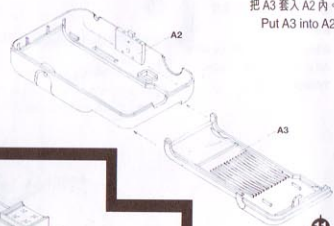

11

進行 B 向裝配時應先把件 P6 推到  
靠上位置且注意不可與配件 A2 相  
碰，否則幼細尾部很易折斷，  
則全部機不能使用。

To facilitate a successful assembly  
in direction B, push part P6 toward  
the upper end and avoid any  
collision against part A2.  
Otherwise breakage of tiny end  
will lead to an unsuccessful  
assembly.

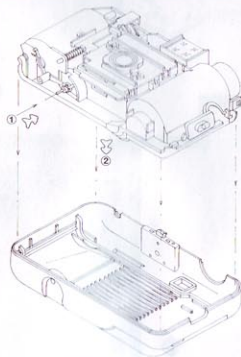

12

7

裝件 A23 時注意件 P6 中心，  
必須對正才能裝入。

When install A23, make sure  
P6 is in central direction.

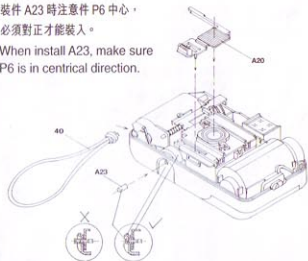

裝件 31 時注意件 A4 孔位，  
必須對正才能裝入。

When install 31, make sure  
A4 is in central direction  
through the hole.

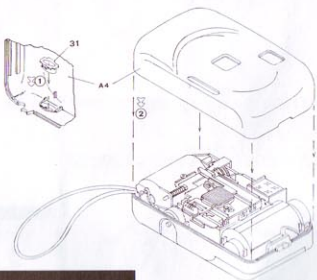

用隨機工具上緊螺絲 S34。  
Employ the bundled tools  
for fastening of screws.

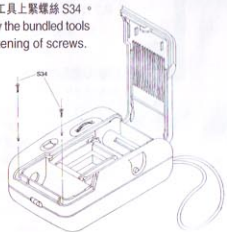

回捲扣裝嵌。  
Film rewind installation.

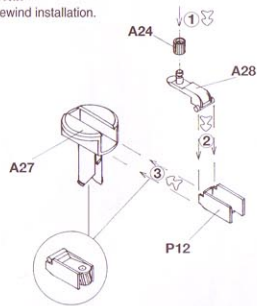

此件為彈性零件裝入時須稍加用力。  
This is an elastic component part.  
Slightly press during assembly.

